

Restrictor Check

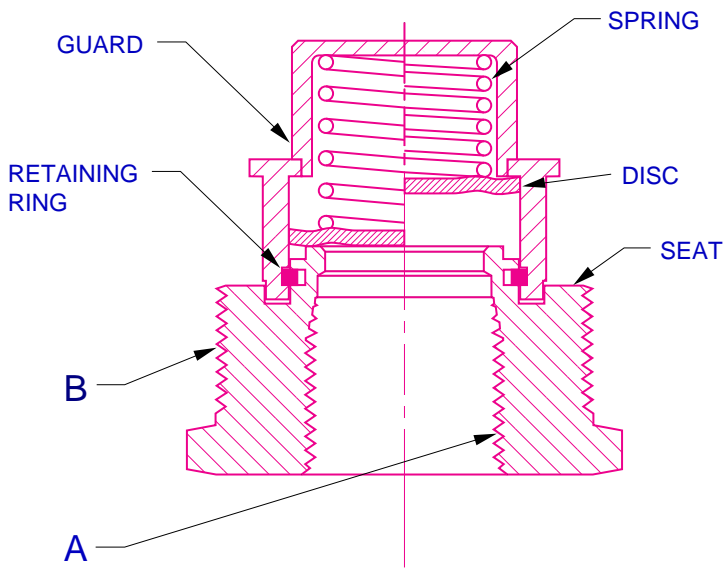

Features:

- Higher cracking pressures (2 to 40 psi)
- 1/4" to 2-1/2" Line size
- 450 to 2500 CWP
- Threaded ends
- Stainless Steel Construction
- Spring-assisted silent closing
- Horizontal or vertical installation
- Tight shut-off - lapped disc & seat
- Easy maintenance
- Versatile
- OPTIONS:
 - Soft seat

The DFT® Restrictor Check Valve (RCV) is a versatile, all-purpose, spring-assisted, in-line check valve for applications that require higher cracking pressures to open the check valve than those offered by other DFT check valves. Cracking pressures are available from 2 to 40 psi. Like the Basic-Check® valve, the Restrictor Check provides reliable, low maintenance service for a wide range of fluids and gases at various pressure/temperature combinations. The valve consists of a guard cage, spring, valve disc, retaining ring and seat. It can be combined with pipe fittings such as couplings, drain elbows, etc. (not provided by DFT) to form a complete check valve unit ideally suited for a broad range of applications. The RCV should not be considered a substitute for a Pressure Relief Valve.

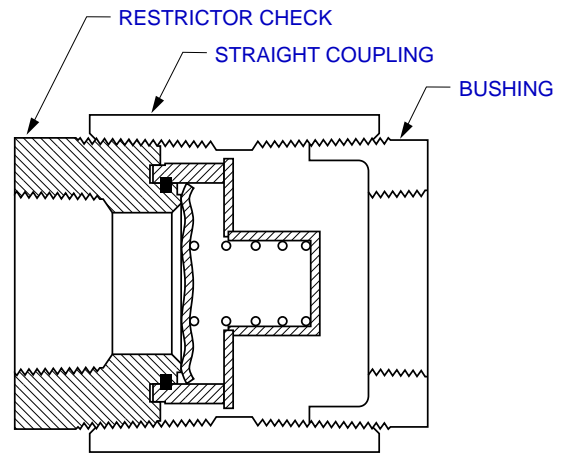

Typical Installation

MATERIALS OF CONSTRUCTION

Model	Seat	Disc	Guard	Spring	Retaining Ring
Restrictor Checks	303 SS	316 SS	316 SS	302 SS	316 SS

Restrictor Check

TECHNICAL INFORMATION

RESTRICTOR CHECK		Friction Loss (Feet of Pipe)	VALVE CRACKING PRESSURE	Approx. Net WT. Each (In lbs.)
Line Size Inlet (FNPT) A	Outside Thread (MNPT) B		(PSI) (± 10%)	
1/4"	1"	7	3.3 to 20.4	.38
3/8"	1"	7	3.3 to 20.4	.38
1/2"	1"	7	3.3 to 20.4	.38
3/4"	1-1/2"	6	3.4 to 15.5	.88
1"	2"	7	4.2 to 40.7	1.25
1-1/4"	2-1/2"	12.5	1.8 to 18.8	2.25
1-1/2"	3"	11	2.4 to 19.1	3.75
2"	4"	16	1.7 to 9.4	7.00
2-1/2"	4"	16	1.7 to 9.4	7.00

Not recommended for use on discharge of reciprocating compressors.

COLD, NON-SHOCK PRESSURE RATING ⁽¹⁾

Size	1/4" 3/8" 1/2"	3/4"	1"	1-1/4"	1-1/2"	2"	2-1/2"
Restrictor Check	2500	2000	1500	850	700	450	450

Sat. Steam Pressure (PSIG) Ref. ⁽²⁾	Tempera- ture (Deg. F.)	Adjusted Rating as Percent of Cold Rating
-3	200	86%
15	250	82%
52	300	78%
232	400	71%
407	450	69%
665	500	66%
1526	600	62%
3075	700	60%

All stainless steel construction is suitable for cryogenic service. For pressure rating at elevated temperatures for standard metal-seated valves, reduce above rating per chart at right.

Maximum valve temperature rating is limited by soft seal (if any) and spring materials in chart below. For ratings of soft seals using some other elastomers, consult factory.

(1) Contingent on service ratings of matching pipe and fittings.

(2) Saturated steam pressure is given for reference only; pressure limit of valve is the adjusted rating at the given temperature.

MAXIMUM OPERATING TEMPERATURES OF MATERIALS					
MATERIALS	SEAL ⁽³⁾			SPRING	
	BUNA-N	VITON®	ZELON	316 SS	INCONEL® X-750
TEMP. °F	-70 to 250	-40 to 400	37 to 400	-460 TO 450	-460 TO 700

(3) Buna-N and Viton are not suitable for steam service.