

Type 950XP Explosion-Proof I/P Transducer

Process-reliable and field rugged

**Now
Approved
for
Natural
Gas**

The Type-950XP Explosion-proof I/P (current to pressure) transducer produces a pneumatic output that is directly proportional to a current input signal. A closed loop pressure feedback control system provides a highly accurate, stable air pressure output for the operation of actuated valves. The unit can mount in any position and is vibration insensitive. It's compact housing and easily accessible ports and adjustments make set-up and installation of the unit simple. An integral volume booster provides high flow capacity, which increases control speed in critical applications.

Features

- **Compact Size**
Installs where others won't
- **Optional Field-Selectable Outputs**
Allows you to stock only one unit for all outputs
- **Modular Construction**
Quick adjustment and repair
- **RFI/EMI Protected**
Eliminates susceptibility to electromagnetic interference
- **Convenient Installation**
Easy wiring and multiple mounting configurations



ControlAir Inc.

Type 950XP

Reliable performance and value in a compact, e

Now, there is a compact I/P transducer that delivers reliable high performance for the toughest applications in the most hazardous environments: the Type 950XP from ControlAir. The 950XP converts an electrical current signal to a stable, pneumatic output to actuate valves. Its NEMA 4X (IP65) housing is designed for both Intrinsically Safe and Explosion-Proof operation. Advanced circuitry includes electronic feedback control for superior vibration protection and highly accurate output.

With flow rates up to 12 SCFM (20m³/hr), the 950XP has the muscle to drive large valves and actuators. It is very economical to operate, consuming only .05 SCFM (0.11m³/hr), which is especially important in natural gas applications.

Its small footprint can fit into tight spots. An optional mounting kit lets you mount it directly on a valve, wall, panel, or 2" pipe. Optional field-selectable process output ranges reduce downtime and inventory. And since the 950XP is position insensitive, it provides even more freedom in mounting and connecting to valves and instruments. As a result of this flexibility, installation goes faster. Easy access Zero and Span adjustments make bench or field calibration quick and easy.

For operating versatility, you may choose direct, reverse, and split range modes. A piezoelectric bimorph actuator and surface-mounted electronics are conveniently mounted on a removable control manifold that allows easy maintenance. The 950XP can be out-of-the-box and up-and-running quickly.

Whether designing a new control system or upgrading an old one, the Type 950XP is the best unit for the job. It is a great combination of performance and value. Get in touch with ControlAir today and one of our application specialists will be happy to discuss your needs.

- Actuator and Control Electronics
- Pilot Pressure
- ▨ Input Pressure
- Output Pressure

The Type-950XP utilizes a nozzle to control a pilot pressure to an integral volume booster. The resultant output pressure is measured by a pressure sensor, which in turn provides a feedback signal to the control circuitry.

The feedback circuit compares this signal to the input signal and self corrects as necessary, thus minimizing the effects of vibration, position, temperature and supply pressure. The current signal flows to the piezo actuator causing it to bend toward the nozzle. This restricts the flow of air through the nozzle and creates back pressure in the pilot pressure chamber. This back pressure acts as a signal pressure which in turn controls the pressure at the output.

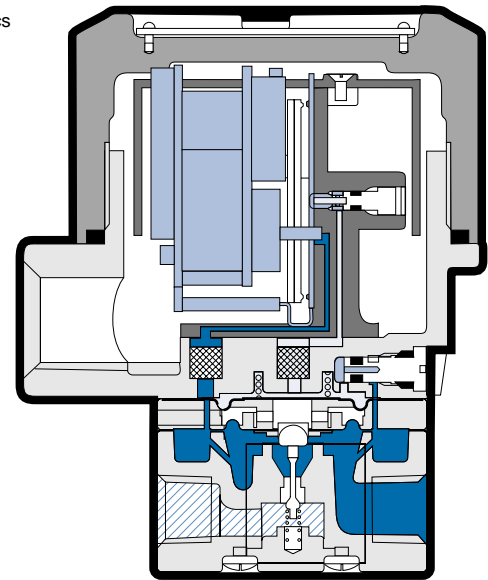

FUNCTIONAL SPECIFICATIONS

Inputs	4-20 mA	
Outputs	3-15 psig	0.20-1.00 BAR
	3-27 psig	0.20-1.80 BAR
	6-30 psig	0.40-2.00 BAR
Air Consumption	3.0 scfh (0.11 m ³ /hr) at mid range	
Supply Pressure	100 psig (7.0 BAR) maximum	
Note:	Supply pressure must be a minimum of 5 psig above maximum output	
Flow Capacity	4.5 scfm (7.6 m ³ /hr) at 25 psig (1.7 BAR) supply 12.0 scfm (20.0 m ³ /hr) at 100 psig (7.0 BAR) supply	
Temperature Limits	Operating	-40° to +160° F (-40° to +71° C)
	Storage	-40° to +200° F (-40° to +93° C)
Loop Load, I/P Transducer	7.5 VDC @ 20 mA	
Operating Modes	direct, reverse and split range (Split ranging not possible with field selectable option)	

Explosion-proof housing

Explosion-proof, NEMA 4X (IP65) housing

Approved for natural gas

RFI/EMI protected

Compact size

Supply pressures up to 100psig

Electronic feedback control for superior shock and vibration resistance

Easy wiring

Optional field-selectable output ranges

Low air consumption

Optional tapped exhaust

High output flow capacity

High accuracy $\pm 0.10\%$ of span

Input/output ports on front and back

Shown actual size with
tapped exhaust option

Position-insensitive - can be mounted in any orientation

PERFORMANCE SPECIFICATIONS

Accuracy, Hysteresis, and Repeatability	$\pm 0.10\%$ of span
Deadband	0.02% of span
Position Effect	No measurable effect
Vibration Effect	Less than $\pm 1.0\%$ of span under the following conditions: 5-15Hz @ 0.8 inches constant displacement; 15-500Hz @ 10g's
Supply Pressure Effect	No measurable effect
Temperature Effect	$\pm 0.045\% / ^\circ\text{F}$ ($0.07\% / ^\circ\text{C}$) of span
Reverse Polarity Effect	No damage from reversal of normal supply current (4-20 mA) or from misapplication of up to 60 mA
RFI/EMI Effect	Less than .5% of span change in output pressure per En 61000-4-3:1998, Amendment 1, Performance Criterion A

PHYSICAL SPECIFICATIONS

Port Sizes	Pneumatic	1/4" NPT
	Electric	1/2" NPT
Media	Clean, dry, oil-free, air-filtered to 40 micron Natural gas when Tapped Exhaust option (E) is ordered and unit is installed in conjunction with an FM/CSA approved conduit seal located within 18" of the unit.	
Mounting	Direct wall, panel, or 2" pipe (optional)	
Materials	Housing	Chromate-treated aluminum with epoxy paint. NEMA 4X (IP65)
	Elastomers	Buna-N
	Trim	Stainless steel; brass; zinc-plated steel
Weight	1.8 lbs (.82 kg)	

Type 950XP

Ordering Information

Type 950XP Dimensions

Use this coding system to order

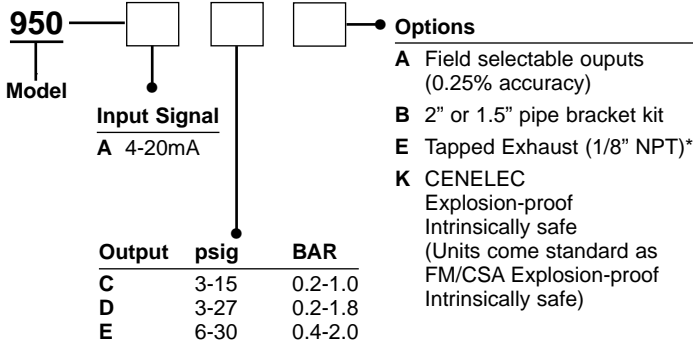

*Tapped Exhaust Unit

FM/CSA approved for use with natural gas (sweet) or methane when used in conjunction with an FM/CSA approved conduit seal located within 18" of the unit.

Accessories

Mounting kit for 1.5" or 2" pipe. Kit # 448-542-005

Conduit Seal Fitting

Potted fitting to prevent natural gas passing from the unit into the conduit. Must be installed within 18" of the unit. Includes 2' of potted wiring to wire into unit and 8' of potted wiring to wire into conduit. Kit # 448-796-001

Hazardous Area Classifications

Factory Mutual (FM) & Canadian Standards Approval (CSA)

Explosion Proof

Class I, Division 1 & 2, Groups B, C & D
Enclosure Nema 4X (IP 65)
Temp. Code T6 Ta = 70° C

Dust Ignition Proof

Class II & III, Division 1, Groups E, F & G
Enclosure Nema 4X (IP 65)
Temp. Code T6 Ta = 70° C

Intrinsically Safe

Class I, Division 1, Groups C & D
Class II, Division 1, Groups E, F, & G
Class III, Division 1, Fibers
Enclosure Nema 4X (IP 65)
Rated 4-20 mA, 30 VDC Max.
Temp. Code T4 Ta = 70° C

Non-Incendive

Class I, Division 2, Groups A, B, C & D
Enclosure Nema 4X (IP 65)
Temp. Code T4 Ta = 70° C

Suitable for

Class II & III, Division 2, Groups F & G
Enclosure Nema 4X (IP 65)
Temp. Code T6 Ta = 70° C

Entity Parameters

U: (Vmax) = 30 VDC Ci = 0 uF
I: (Imax) = 125 mA Li = 0 mH
Pi = .7 w

CENELEC Approval (KEMA)*

Explosion Proof

EEx d IIB + H2
Enclosure Nema 4X (IP 65)
Temp. Code T4

Intrinsically Safe

Ex ia IIB
Temp. Code T4

Entity Parameters

Umax = 28 VDC C = 0 uF
Imax = 100 mA L = 0 mH

* Approval pending 4/03

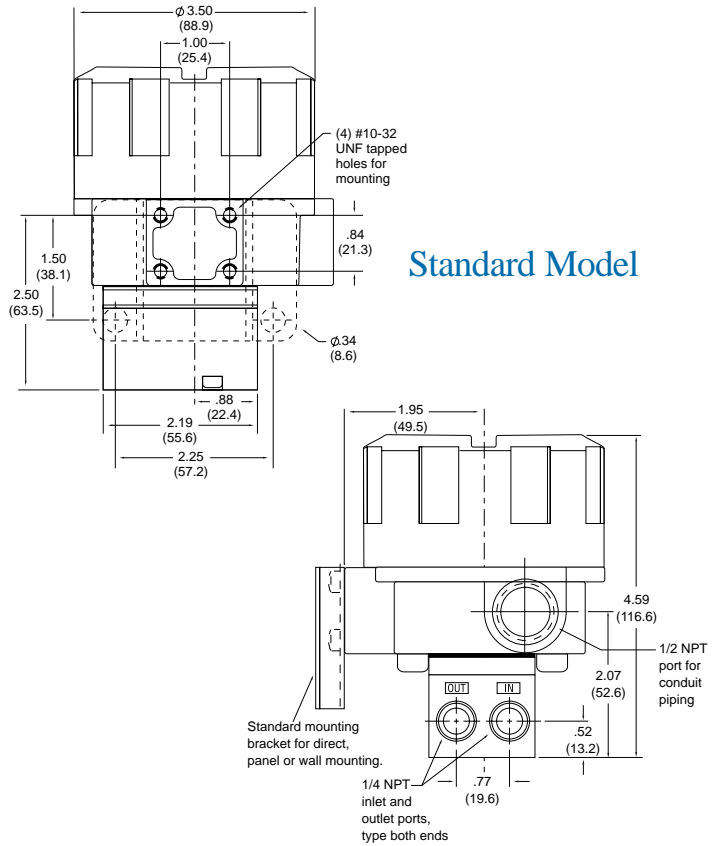

With Tapped Exhaust Option

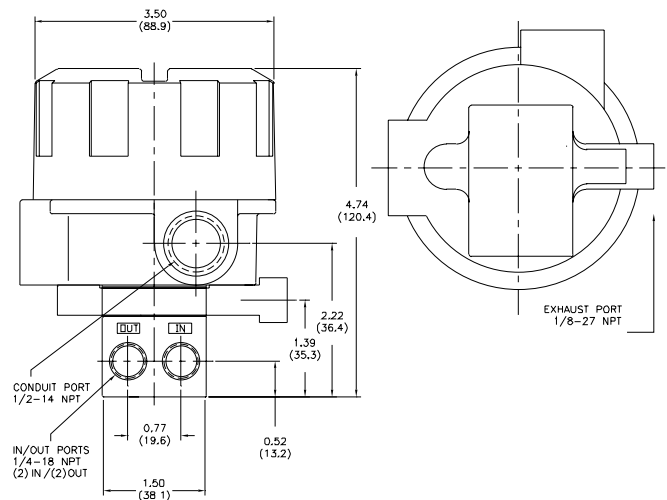

Drawing downloads available at www.controlair.com



8 Columbia Drive / Amherst, NH 03031 USA
Website: www.controlair.com
Email: sales@controlair.com
603-886-9400 FAX 603-889-1844

