

FlowProducts

Sensor Technology

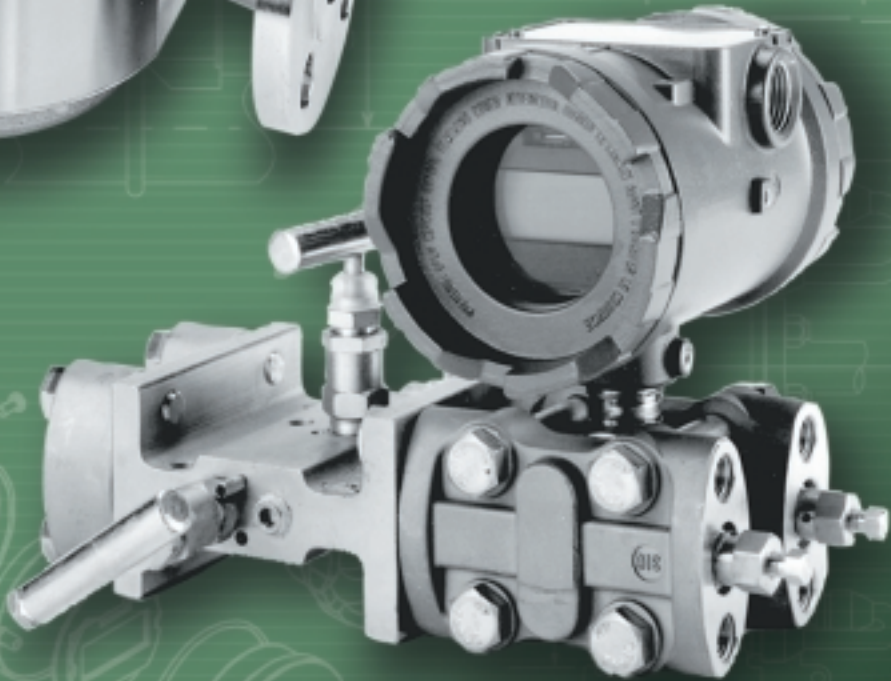

OPTIMUX

MODELS

Model V30D & V40D Differential Pressure

- ▶ Spans from 0.2" H₂O to 450 PSID (0.05 to 3100 KPA)
- ▶ Standard Hastelloy-C diaphragms and 316SS wetted parts (Ranges D & F)
- ▶ 1/4" NPTF or 1/2" NPTF process connection
- ▶ Suitable for DP, level, and flow applications

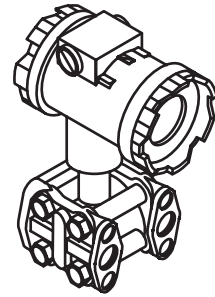

Model V30D & V40D Differential Pressure with Integral Orifice Assemblies

- ▶ Six integral orifice sizes
- ▶ 316 SS construction
- ▶ 1/2" NPTF process connection
- ▶ "Wet" calibrations available
- ▶ Suitable for low-flow applications

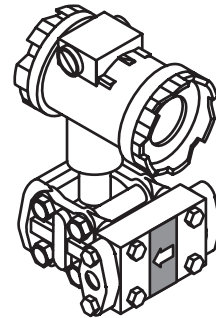

Model V30D & V40D Differential Pressure with Integral 3-Valve Manifold

- ▶ Factory mounted
- ▶ 316SS or CS construction

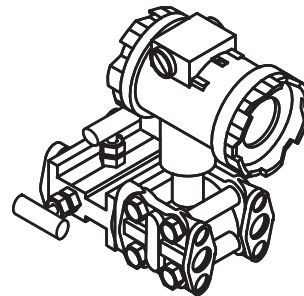

SPECIFICATIONS

PERFORMANCE SPECIFICATIONS

Reference conditions: Zero-based, positive spans, ambient temperature 23°C, D/A trim values equal to span end points, Silicone fill, standard diaphragms, 1 second damping.

Reference Accuracy^{1,2}

Range A:

- ± 0.1% of calibrated span for spans from 1:1 to 2:1 of URL
- ± (0.074 + 0.013[URL/Span]) % of calibrated span for spans from 2:1 to 25:1 of URL

Range B:

- ± 0.075% of calibrated span for spans from 1:1 to 2.5:1 of URL
- ± (0.043 + 0.0128 [URL/span]) % of calibrated span for spans from 2.5:1 to 20:1 of URL

Range D,F,G:

- ± 0.075% of calibrated span for spans from 1:1 to 10:1 of URL
- ± (0.028 + 0.0047 [URL/span]) % calibrated span for spans from 10:1 to 45:1 of URL

Digital Output

Range A:

- ± 0.0875% of calibrated span for spans from 1:1 to 2:1 of URL
- ± (0.0615 + 0.013[URL/Span]) % of calibrated span for spans from 2:1 to 25:1 of URL

Range B:

- ± 0.0625% of calibrated span for spans from 1:1 to 2.5:1 of URL
- ± (0.0305 + 0.0128 [URL/span]) % of calibrated span for spans from 2.5:1 to 20:1 of URL

Range D,F,G:

- ± 0.0625% of calibrated span for spans from 1:1 to 10:1 of URL
- ± (0.0155 + 0.0047 [URL/span]) % calibrated span for spans from 10:1 to 45:1 of URL

Ambient Temperature Effect

Models V30D, V40D

Ranges A-B:

- ±(0.175% URL + 0.075% span) per 28°C (50°F)

Ranges D-G:

- ±(0.075% URL + 0.075% span) per 28°C (50°F)

Temperature Limits

Sensor Assembly³:

- Silicon: -40 to 125°C (-40 to 257°F)
- Inert Fill: 0 to 85°C (32 to 185°F)
- Paratherm: -20 to 125°C (-4 to 257°F)
- Electronics: -40 to 85°C (-40 to 185°F)

Stability

Zero Stability:

- Range A: ±0.1% of URL for 12 months
- Ranges B-G: ±0.03% of URL for 36 months
- Span Stability: No Measurable Span Drift

Humidity

0-100% relative humidity, non-condensing

Vibration Effect

Less than ±0.05% of maximum span per G for 0 to 60 Hz in any axis up to 2 Gs max.

Power Supply Effect

Less than 0.005% of output span per volt

EMI/RFI Susceptibility

Less than 0.25% of max. span at 30 V/m, 30 MHz - 1 GHz

ESD Susceptibility

IEC severity level 4, 15 kV

Static Pressure Effect (V30D & V40D)

Range Span Error Correctable To:³

- B 0.2% per 100psi
- D 0.2% per 1000psi
- F 0.2% per 1000psi

NOTES:

- (1) Accuracy includes the effects of linearity, hysteresis and repeatability.
- (2) Limit to 85°C (185°F) in vacuum service.
- (3) Zero effect eliminated at operating pressure.

Specifications are subject to change without notice.

FUNCTIONAL SPECIFICATIONS

Range and Sensor Limits Model V30D, V40D

Range	Min. Span	LRL/URL V30/V40D
A	0.20" (.05KPA)	-2/5" (5/1.25KPA)
B	0.75" (0.185KPA)	-15/15" (-3.7/3.7KPA)
D	10" (2.5KPA)	-450/450" (-112.5/112.5KP)
F	12.6psi (87KPA)	-150/450psi (-689/3100KPA)

Zero Elevation and Suppression

The range may be set anywhere between the LRL and URL of the transmitter, so long as the calibrated span meets the minimum allowable span in the table above. Zero and span in the XTC are non-interactive.

Electronic Damping (Digital Filter)

Adjustable between 0 and 30 seconds

Transmitter Outputs

Each transmitter has:

1. Analog, Two-Wire 4-20mA
2. Digital, HART Communications
3. Optional Transient Suppressor

Power Supply Requirements

Minimum Terminal to Terminal Compliance

Voltage: +10 Vdc

Maximum Terminal to Terminal Voltage: +42 Vdc

Maximum Load: $RL = 50 * (\text{Supply Voltage})$

- 500 Ohms¹

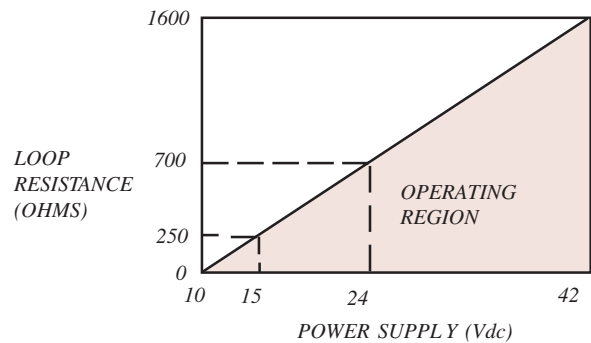

Maximum Working Pressure²

Range	V30/V40D
A	+/-60 psi ³ (+/-413KPA)
B	+/-100 psi ³ (+/-689KPA)
D	+/-4000 psi (+/-27.6MP A)
F	+/-4000 psi (+/-27.6MP A)

NOTES:

(1) To ensure digital communications, HART requires the loop resistance to remain between 250 and 1100 Ohms. HART also imposes the following requirements on the loop power supply:

Ripple: 0.2 Vp-p, 47-125 Hz
Noise: 0.6 mV RMS maximum
Impedance: 10 Ohms maximum

(2) The Maximum Working Pressure (MWP) is defined as the maximum pressure which can be applied to the cell without damage, static or otherwise.

(3) V40D Range A and Range B sensors have a body rating of +/- 4000 psi; however, no over pressure protection is employed in these units thereby limiting the MWP to +/- 100 psi.

Surge Protection

(with optional Transient Suppressor)

- Maximum clamping voltage (either loop terminal to enclosure)
 - DC: 68V
 - 100 kV per microsecond AC surge: 70V peak
 - 1000 kV per microsecond AC surge: 120V peak
- Transient surge current
 - Up to 5000 amp for 20 microseconds, repeated strikes
- Turn-On Time
 - The transmitter will begin operating within 5 seconds after power is applied. The transmitter will perform within specifications within 60 seconds after power is applied.

Local Indication

- Optional 4 1/2 Digit SmartDisplay

MECHANICAL SPECIFICATIONS

Dimensions

- See Installation Drawings (Pages 97-99)

Weight³

- V40D 7 lbs

Electronics Housing

- Epoxy Powder Coated, Low Copper Cast Aluminum
- 316 SS (optional)
- NEMA 4X/6P (IP66/68)
- (2) 1/2" -14 NPTF Electrical Conduit Entrances (M20 x 1.5 optional)

Process Wetted Parts

- Various Materials Available
- NACE MR0175 compliant with options as noted in the model number breakdown.

Hazardous Area Classification/Approvals⁴

- FM/CSA Approval:
 - Intrinsically Safe:
 - Class I, Div. 1, Groups A, B, C, & D
 - Class II, Div. 1, Groups E, F & G
 - Class III, Div. 1
 - Explosion Proof:
 - Class I, Div. 1, Groups B, C, & D
 - Class II, Div. 1, Groups E, F, & G
 - Class III, Div. 1
 - Non-Incendive:
 - Class I, Div. 2, Groups A, B, C, & D

American Bureau of Shipping (ABS) type approval per 2002 steel vessel rules 4-9-2/11.3

NOTES:

- (1) At 100°F (38°C), the rating decreases with increasing temperature.
- (2) At 120°C, the rating decreases with increasing temperature.
- (3) Weights approximate.
- (4) Consult OPTIMUX for information and additional approvals

Differential Pressure

V30D Differential Pressure Transmitter

Input Range: Span Limits, Min/Max

- A 0.2/5 "H₂O (0.05/1.25 KPA)¹⁰ (Remote seals not available with this range.)
- B 0.75/15 "H₂O (0.185/3.7 KPA)² (Matched remote seals only with this range.)
- D 10/450 "H₂O (2.5/112.5 KPA)²
- F 12.6/450 psi (87/3100 KPA)²

Output

- B 4-20 mA_{dc} with HART Protocol^{1,2}
- C 4-20 mA_{dc} with HART Protocol & Integral Transient Suppressor
- D Spare Capsule

Process Diaphragm

- H Hastelloy C-276^{2,3,8,11}
- S 316L SS^{2,7}
- A Hastelloy C-276 with 2 Remote Seals^{9,11}
- B Hastelloy C-276 with 1 Remote Seal on high side^{9,12}
- C Hastelloy C-276 with 1 Remote Seal on low side^{9,12}

Body Parts

	Wetted	Vent/Drain	Process Conn.
AA	316SS	End	1/2 NPT ^{1,2}
AB	316SS	Side (top)	1/2 NPT
AC	316SS	Side (bottom)	1/2 NPT
AD	316SS	Side (dual)	1/2 NPT
AE	316SS	End	1/4 NPT
AF	316SS	Side (top)	1/4 NPT
AG	316SS	Side (bottom)	1/4 NPT
AH	316SS	Side (dual)	1/4 NPT
BA	Hastelloy C-276	End	1/2 NPT
BB	Hastelloy C-276	Side (top)	1/2 NPT
BC	Hastelloy C-276	Side (bottom)	1/2 NPT
BD	Hastelloy C-276	Side (dual)	1/2 NPT
BE	Hastelloy C-276	End	1/4 NPT
BF	Hastelloy C-276	Side (top)	1/4 NPT
BG	Hastelloy C-276	Side (bottom)	1/4 NPT
BH	Hastelloy C-276	Side (dual)	1/4 NPT
RR	Remote Seals		

Fill Fluid

- B Silicone DC200^{1,2}
- C Inert¹¹
- D Paratherm¹¹

Output Indicator

- 5 4-1/2 Digit Digital SmartDisplay²
- N Not Required⁵

Standard Options

- D B7M Bolts³
- E B8M Bolts¹⁷
- X Oxygen Cleaned¹⁹
- Y Special Features⁴
- N Not Required^{2,5}

Mounting Bracket

- 1 2" Pipe Mount Bracket with SS Hardware²
- 2 Universal Bracket
- 3 2" Pipe Mount 316SS Bracket
- N Not Required⁵

Housing

- 1 Aluminum 1/2" - 14 NPT^{1,2}
- 2 Aluminum M20 x 1.5⁶
- 3 316 SS 1/2" - 14 NPT
- 4 316 SS M20 x 1.5⁶
- N Not Required⁵

Hazardous Area Classification

- 2 CSA/CRN
- 3 FM/CSA All^{1,2}
- N Non-Approved
- W FM/CSA All & ABS¹⁸ Type Approved

NOTES:

- (1) Standard for all ranges.
- (2) Stock Model Selection.
- (3) NACE MR0175 compliance requires this option.
- (4) Please describe the modification or provide a quotation reference number.
- (5) Required selection for OUTPUT option "D", direct connection to the OPTIMUX V348.
- (6) Not available with FM/CSA approvals.
- (7) Standard on Input Ranges A & B.
- (8) Standard on Input Ranges D & F.
- (9) Must specify Body Parts code "RR".
- (10) Must select Body Parts "AA".
- (11) Not available with Input Range "A".
- (12) Not available with Input Range "A" or "B".
- (13) Available with Body Parts "TD" or "TE" only.
- (14) CENELEC EExd & SAA units are only available with OUTPUT code "B".
- (15) 2" Flanges not available with extended diaphragms.
- (16) 3" and 4" flanges with an extension will fit into Schedule 80 and larger i.d. pipes.
- (16) 3" and 4" flanges with an extension will fit into Schedule 80 and larger i.d. pipes.
- (18) ABS - American Bureau of Shipping.
- (19) Oxygen Cleaned option requires inert fill fluid.

V30D D B H AA B 5 N 1 1 3 Sample Model Number

Differential Pressure

V40D Differential Pressure Transmitter

Input Range: Span Limits, Min/Max

- A 0.2/5 "H₂O (0.05/1.25 KPA)¹⁰ (Remote seals not available with this range.)
- B 0.75/15 "H₂O (0.185/3.7 KPA)² (Matched remote seals only with this range.)
- D 10/450 "H₂O (2.5/112.5 KPA)²
- F 12.6/450 psi (87/3100 KPA)²

Output

- B 4-20 mAdc with HART Protocol^{1,2}
- C 4-20 mAdc with HART Protocol & Integral Transient Suppressor
- D Spare Capsule

Process Diaphragm

- H Hastelloy C-276^{2,3,8,11}
- S 316L SS^{2,7}
- A Hastelloy C-276 with 2 Remote Seals^{9,11}
- B Hastelloy C-276 with 1 Remote Seal on high side^{9,12}
- C Hastelloy C-276 with 1 Remote Seal on low side^{9,12}

Body Parts

	Wetted	Vent/Drain	Process Conn.
AA	316SS	End	1/2 NPT ^{1,2}
AB	316SS	Side (top)	1/2 NPT
AC	316SS	Side (bottom)	1/2 NPT
AD	316SS	Side (dual)	1/2 NPT
AE	316SS	End	1/4 NPT
AF	316SS	Side (top)	1/4 NPT
AG	316SS	Side (bottom)	1/4 NPT
AH	316SS	Side (dual)	1/4 NPT
BA	Hastelloy C-276	End	1/2 NPT
BB	Hastelloy C-276	Side (top)	1/2 NPT
BC	Hastelloy C-276	Side (bottom)	1/2 NPT
BD	Hastelloy C-276	Side (dual)	1/2 NPT
BE	Hastelloy C-276	End	1/4 NPT
BF	Hastelloy C-276	Side (top)	1/4 NPT
BG	Hastelloy C-276	Side (bottom)	1/4 NPT
BH	Hastelloy C-276	Side (dual)	1/4 NPT
RR	Remote Seals		

Fill Fluid

- B Silicone DC200^{1,2}
- C Inert¹¹
- D Paratherm¹¹

Output Indicator

- 5 4-1/2 Digit Digital SmartDisplay²
- N Not Required⁵

Standard Options

- D B7M Bolts³
- E B8M Bolts¹⁷
- X Oxygen Cleaned¹⁹
- Y Special Features⁴
- N Not Required^{2,5}

Mounting Bracket

- 1 2" Pipe Mount Bracket with SS Hardware²
- 2 Universal Bracket
- 3 2" Pipe Mount 316SS Bracket
- N Not Required⁵

Housing

- 1 Aluminum 1/2" - 14 NPT^{1,2}
- 2 Aluminum M20 x 1.5⁶
- 3 316 SS 1/2" - 14 NPT
- 4 316 SS M20 x 1.5⁶
- N Not Required⁵

Hazardous Area Classification

- 2 CSA/CRN
- 3 FM/CSA All^{1,2}
- N Non-Approved
- W FM/CSA All & ABS¹⁸ Type Approved

NOTES:

- (1) Standard for all ranges.
- (2) Stock Model Selection.
- (3) NACE MR0175 compliance requires this option.
- (4) Please describe the modification or provide a quotation reference number.
- (5) Required selection for OUTPUT option "D", direct connection to the OPTIMUX V348.
- (6) Not available with FM/CSA approvals.
- (7) Standard on Input Ranges A & B.
- (8) Standard on Input Ranges D & F.
- (9) Must specify Body Parts code "RR".
- (10) Must select Body Parts "AA".
- (11) Not available with Input Range "A".
- (12) Not available with Input Range "A" or "B".
- (13) Available with Body Parts "TD" or "TE" only.
- (14) CENELEC EExd & SAA units are only available with OUTPUT code "B".
- (15) 2" Flanges not available with extended diaphragms.
- (16) 3" and 4" flanges with an extension will fit into Schedule 80 and larger i.d. pipes.
- (16) 3" and 4" flanges with an extension will fit into Schedule 80 and larger i.d. pipes.
- (18) ABS - American Bureau of Shipping.
- (19) Oxygen Cleaned option requires inert fill fluid.

V40D D B H AA B 5 N 1 1 3 Sample Model Number

MODEL DIFFERENCES & MODIFICATIONS

If no range is selected, the instrument will be calibrated as follows:

Range Code	Default Calibration
A	-0.5 to 0.5 H ₂ O
B	0 to 10 H ₂ O
D	0 to 100 H ₂ O (or H ₂ Oabs)
F	0 to 100 PSI (or PSIA)

Common modifications can be specified by selecting a Y in the Special Features category and describing the modification. **Always consult your salesperson before ordering a modification.**

TRANSMITTER COMPONENTS

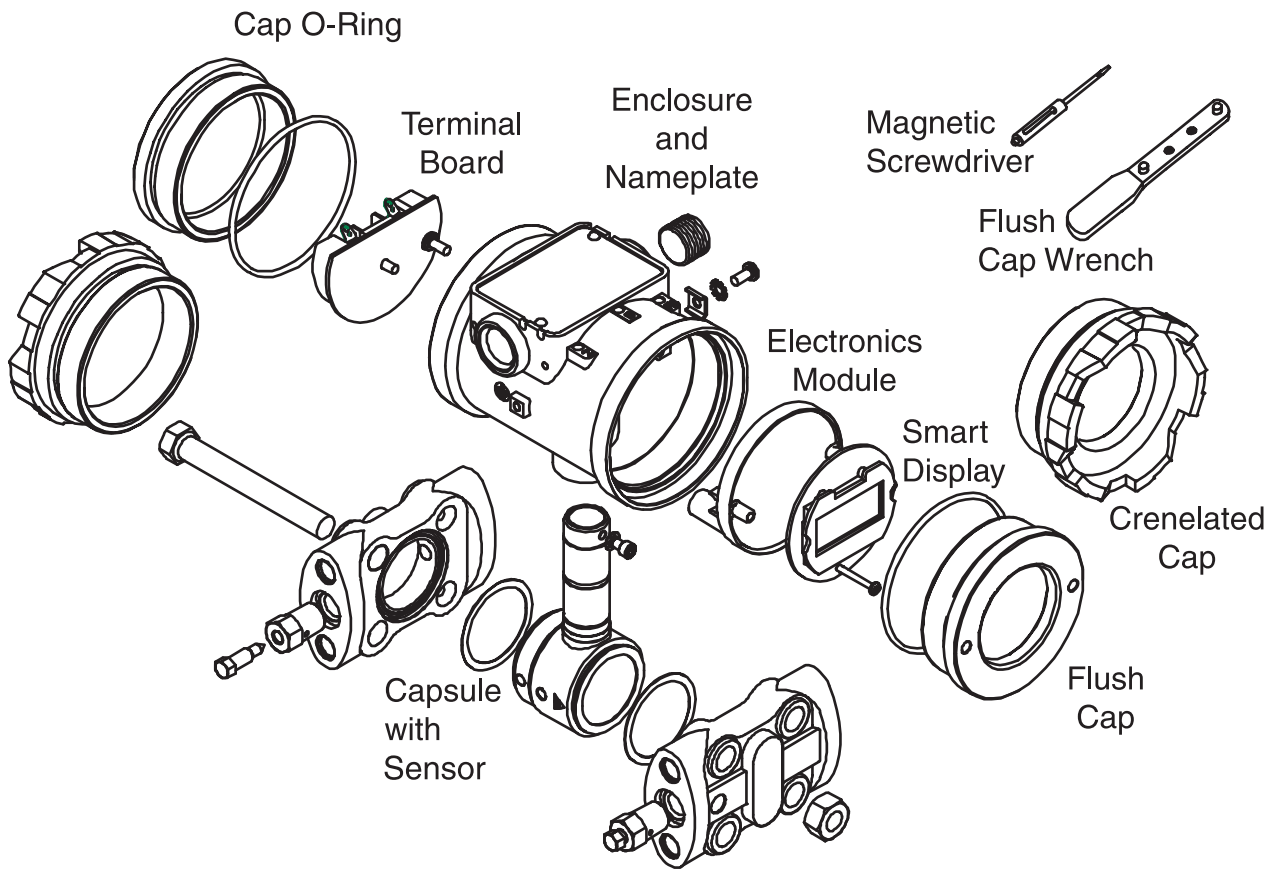

Mount to Bracket with 7/16"-20 Bolts and Lockwashers, 4 places

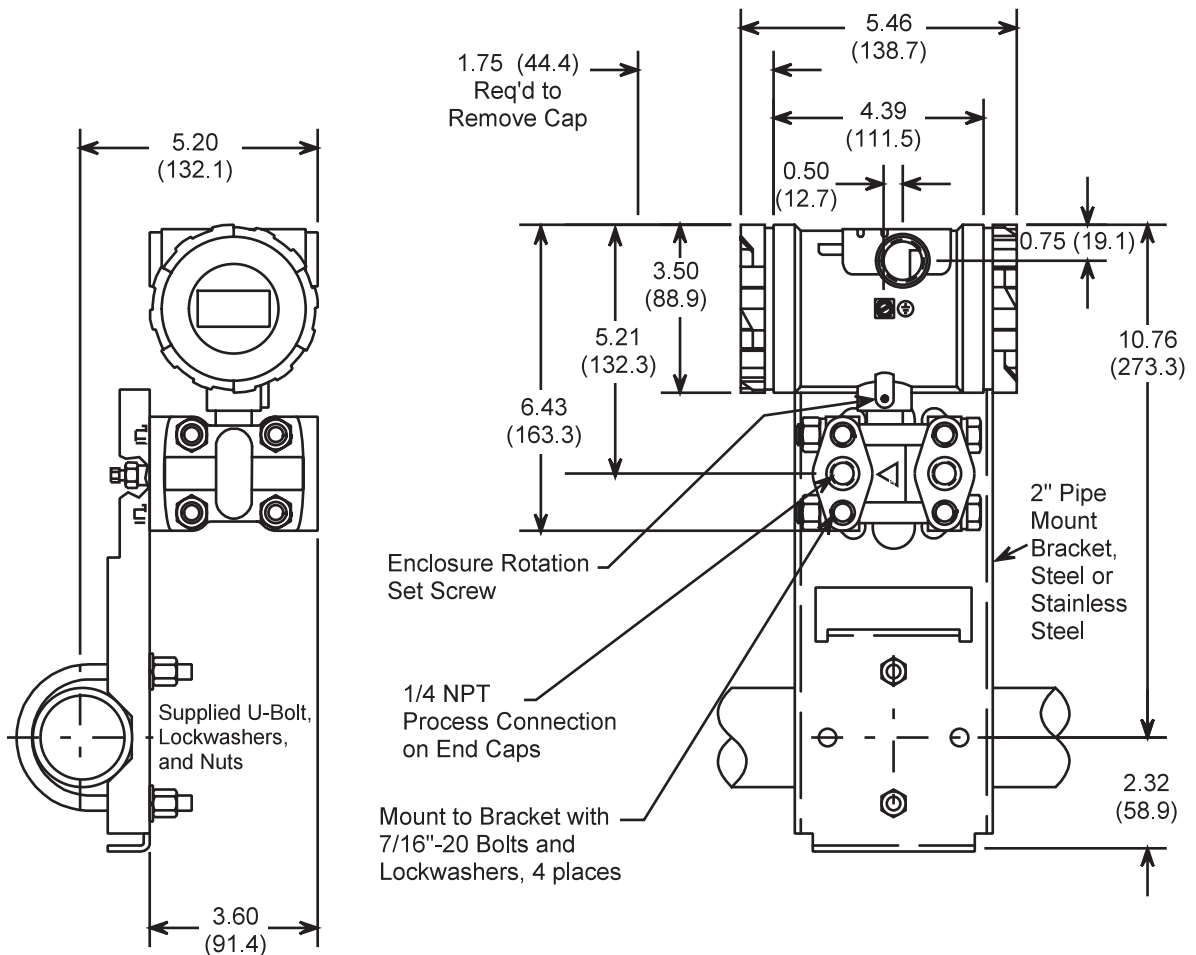
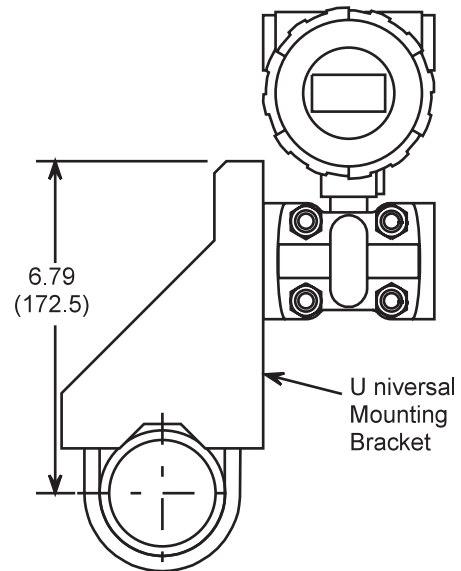
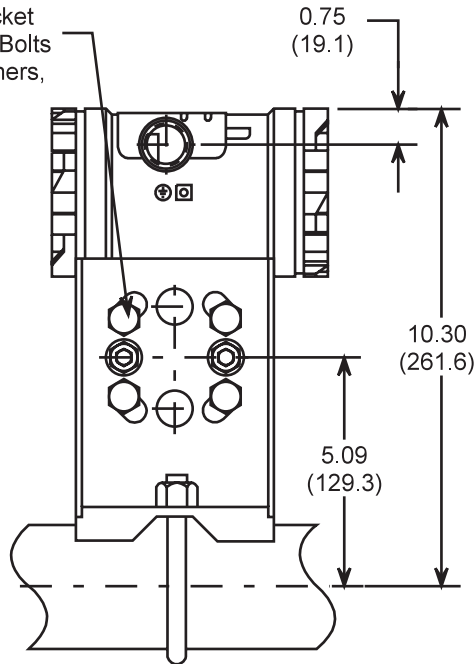

Dimensions are in inches (millimeters).

Model V30D and V40D

OPTIMUX V40S

FEATURES & BENEFITS

- ▶ Rotatable NEMA 4X/6P, IP66/68 housing ensures long, trouble-free operation in harsh environments
- ▶ Rotatable SmartDisplay indicating mass flow (#/hr, kg/hr), energy flow (BTU, kJ/hr), and flow total provides greater operator understanding and maximum flexibility in mounting options
- ▶ Local zero/span/damping delivers simple calibration without requiring a handheld
- ▶ Fully interchangeable components reduce inventory costs
- ▶ High-grade wetted materials necessitate fewer transmitter configurations and facilitate easy specification
- ▶ FM/CSA approvals ensure safe operation
- ▶ Built-in steam tables facilitate easy configuration while requiring minimal user input
- ▶ 14-segment characterizer linearizes nonlinear flow elements and valves
- ▶ Built-in square root extractor accommodates orifice plates
- ▶ The ability to perform on-line zero calibration adjustments without removing pressure simplifies maintenance and calibrations

DESCRIPTION

The OPTIMUX V40S is a differential pressure type flowmeter capable of measuring saturated steam flow. As such, it combines accurate, reliable differential pressure measurement with standard steam flow calculations.

The V40S can calculate and transmit mass flow, energy flow, or differential pressure with a standard 4-20 mA output signal. It can also locally display static pressure, mass flow total, and energy flow total. Moreover, these three variables are available to other smart devices via the HART.®



SPECIFICATIONS

PERFORMANCE SPECIFICATIONS

Reference conditions: Zero-based, positive spans, ambient temperature 23°C, D/A trim values equal to span end points, Silicon fill, Hastelloy-C276 Diaphragms, 1 second damping.

Accuracy¹

- ± 0.1 % of calibrated span for spans from 1:1 to 10:1 of URL
- ± (0.028 + 0.072 (URL/span))% of span for spans from 10:1 to 45:1 of URL

Specifications are subject to change without notice.

Ambient Temperature Effect

±(0.075% URL + 0.075% span) per 28°C (50°F)

Temperature Limits

Sensor Assembly: -40 to 125°C (-40 to 257°F)
 Electronics Assembly: -40 to 85°C

Static Pressure Effect

The OPTIMUX V40S is characterized up to 500 PSI static pressure and accurately compensates the dp signal. For SPE data above 500 PSI operation, consult OPTIMUX.

Stability

Zero Stability: ±0.1% of URL for 12 months
 Span Stability: No measurable Span Drift

Humidity

0-100% relative humidity, non-condensing

Vibration Effect

Less than ±0.05% of maximum span per G for 0 to 60 Hz in any axis up to 2Gs max

Power Supply Effect

Less than 0.005% of output span per volt

EMI/RFI Susceptibility

Less than 0.25% of maximum span at 30V/m, 30 MHz - 1GHz

ESD Susceptibility

IEC severity level 4, 15kV

FUNCTIONAL SPECIFICATIONS

Ranges & Sensor Elements

Range	LRL/URL ²	Minimum SPAN	TD ³	MWP ⁴
D	-450/450 "H ₂ O	10 "H ₂ O	45:1	±4000PSIG
	-112/112 kPa	2.49 kPa		±27.6 MPa

Zero Elevation and Suppression

The range may be set anywhere between the LRL and URL of the transmitter, so long as the calibrated span meets the minimum allowable span in the table above (see table). Zero and span in the OPTIMUX V40S are non-interactive.

Electronic Damping (Digital Filter)

Adjustable between 0 and 30 seconds

Transmitter Outputs

Each transmitter has:

- ▶ Analog, two-wire 4-20mA that can be set to transmit differential pressure, mass flow or energy flow
- ▶ Digital, HART communications that can be used to read static pressure, mass total and energy total
- ▶ Optional transient suppressor

Power Supply Requirements

Minimum Terminal to Terminal Compliance Voltage: +10 Vdc
 Maximum Terminal to Terminal Voltage: +42 Vdc
 Maximum Load: $R_L = 50V_s - 500 \text{ Ohms}^5$

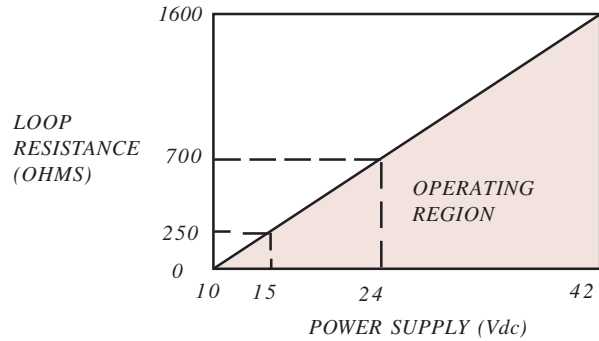

Turn-On Time

The transmitter will begin operating within 5 seconds after power is applied. The transmitter will perform to specifications within 60 seconds after power is applied.

Local Indication

Optional 4-1/2 Digit SmartDisplay will indicate mass flow, energy flow, mass total, and energy total.

Surge Protection (with optional Transient Suppressor)

Maximum clamping voltage (either loop terminal to enclosure)
 DC: 68V
 AC (100 kV/microsecond surge): 70V peak
 AC (1000 kV/microsecond surge): 120V peak

NOTES:

- (1) Accuracy includes the effects of linearity, hysteresis, and repeatability.
- (2) LRL/URL are the lower range limit and upper range limit of the cell, respectively.
- (3) TD is the turndown defined as URL/Minimum Span.
- (4) MWP is the maximum working pressure of the cell. This value represents the maximum pressure that should be applied to the cell as overpressure, static pressure, or otherwise.
- (5) To ensure digital communications, HART requires the loop resistance to remain between 250 and 1100 Ohms. In addition, HART imposes the following criteria on the loop power supply:
 Maximum Ripple: 0.2 Vp-p, 47-125 HZ
 Maximum Noise: 0.6 mV RMS
 Maximum Impedance: 10 ohms

MECHANICAL SPECIFICATIONS

Dimensions

See Drawing

Weight

7 lbs (4.5 kg)

Electronics Housing

Epoxy Powder Coated, Low Copper Cast

Aluminum

NEMA 4X/6P (IP66/68)

(2) 1/2" - 14 NPTF Electrical Conduit Entrances
(M20x1.5 Optional.)

Process Wetted Parts

Diaphragm: Hastelloy-C276

Wetted Parts: 316SS

Process Connections

(2) 1/4" NPTF with vent/drains. (1/2" NPTF with optional process adapters)

Hazardous Area Classification

FM/CSA Approval:

Intrinsically Safe: Class I, Div 1, Groups A, B, C & D

Class II, Div 1, Groups E, F & G

Class III, Div 1

Explosion Proof: Class I, Div 1, Groups B, C & D

Class II, Div 1, Groups E, F & G

Class III, Div 2

Non-Incendive: Class I, Div 2, Groups A, B, C & American Bureau of Shipping (ABS) type approved per 2002 steel vessel rules 4-9-2/11.3

MODEL NUMBER

V40S Differential Pressure Type Flowmeter

Input Range: Span Limits Min/Max

D 10/450 "H2O

Output

B 4-20 mAdc with HART Protocol²

C 4-20 mAdc with HART Protocol & Integral

Transient Suppressor

Process Diaphragm

H Hastelloy-C276

Body Parts

	Wetted	Vent Drain	Process Connection
AA	316SS	End	1/2" NPT ²
AB	316SS	Side (top)	1/2" NPT
AC	316SS	Side (bottom)	1/2" NPT
AD	316SS	Side (dual)	1/2" NPT
AE	316SS	End	1/4" NPT
AF	316SS	Side (top)	1/4" NPT
AG	316SS	Side (bottom)	1/4" NPT
AH	316SS	Side (dual)	1/4" NPT

Fill Fluid

B Silicone DC200

Output Indicator

5 4 1/2 Digit Digital SmartDisplay

N Not Required

Standard Options

Y Special Features³

N Not Required

Mounting Bracket

1 2" Pipe Mount Bracket with SS Hardware

2 Universal Bracket

3 2" Pipe Mount 316SS Bracket

N Not Required

Housing

1 Aluminum 1/2" - 14 NPT

2 Aluminum M20 x 1.5⁴

3 316 SS 1/2" -14 NPT

4 316 SS M20 x 1.5⁴

Hazardous Area Classification

3 FM/CSA All¹

N Non-Approved

W FM/CSA All & ABS⁵ Type Approval

V40S D B H AA B N N 1 1 3 *Sample Model Number*

NOTES:

- (1) Consult OPTIMUX for information on additional approvals.
- (2) Standard for all ranges.
- (3) Please describe the modification or provide a quotation reference number.
- (4) Not available with FM/CSA approvals.
- (5) ABS - American Bureau of Shipping

INSTALLATION DRAWINGS

Mount to Bracket with 7/16"-20 Bolts and Lockwashers, 4 places

Dimensions are in inches (millimeters).

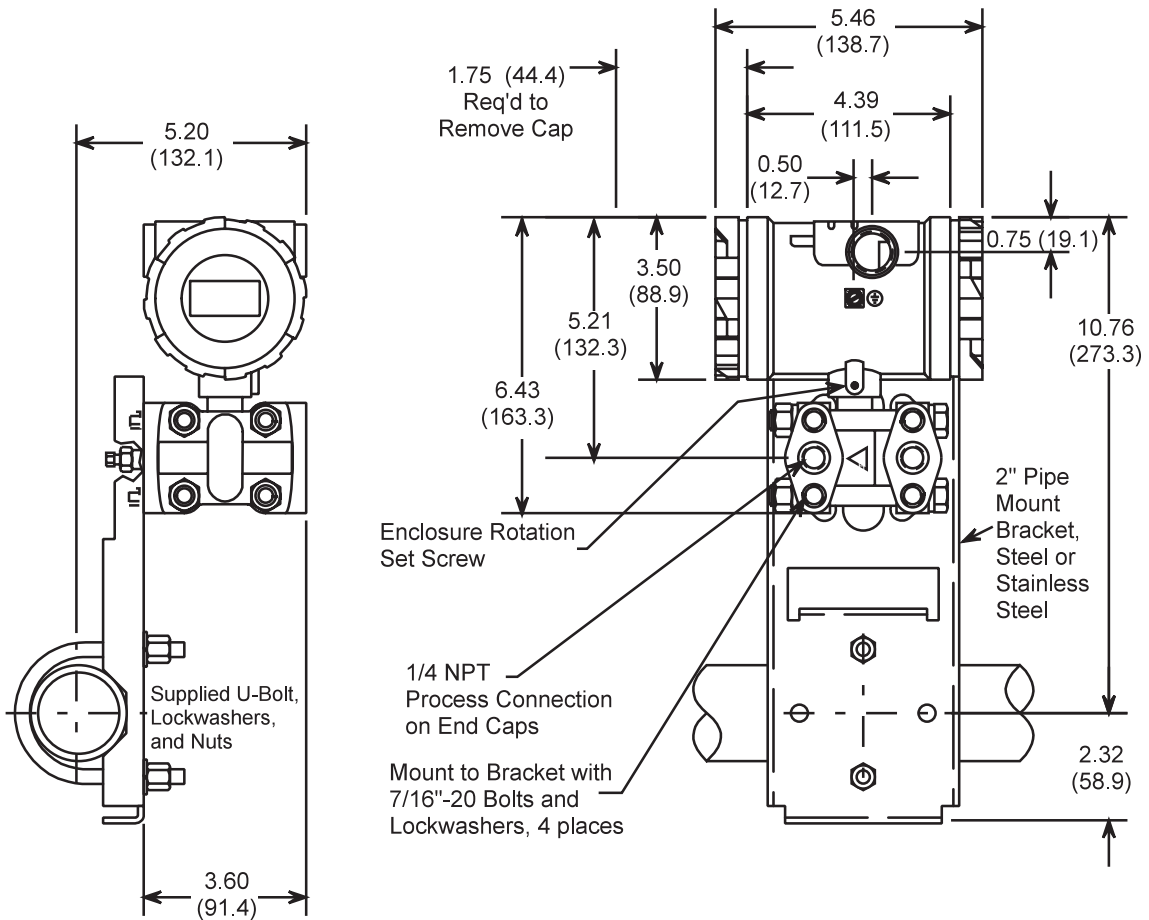
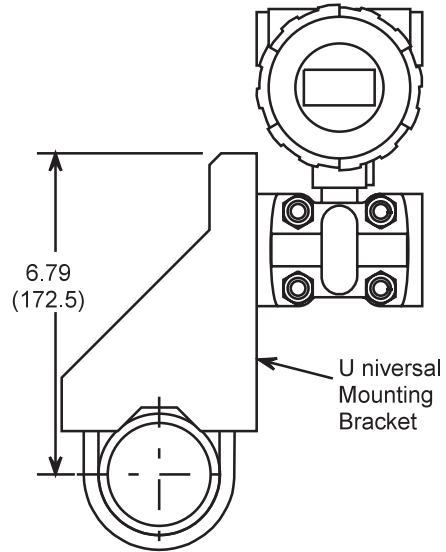
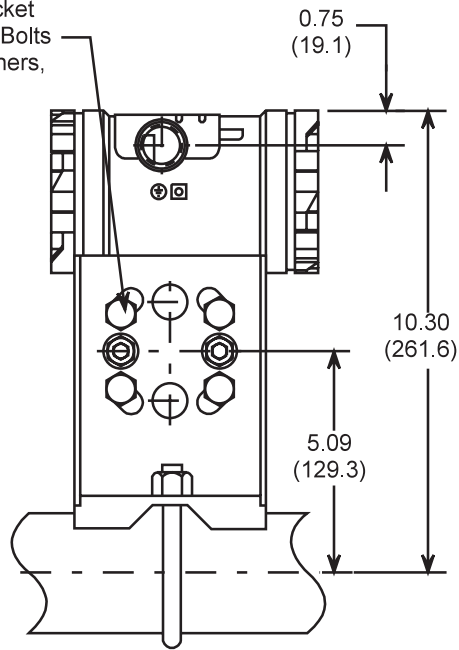

Model V40S

Integral Orifice Assembly for Differential Pressure Transmitters

FEATURES & BENEFITS

- ▶ Compatible with differential pressure transmitters having 2-1/8" process connection centers
- ▶ Operates in static pressure of up to 2000 psig
- ▶ Provides easiest method of orifice installation and removal
- ▶ The ability to mount directly on meter body or through an equalizing manifold provides installation and application versatility
- ▶ Interchangeable between orifices in the XTC family
- ▶ Conforms to NACE Standard MR-01-75

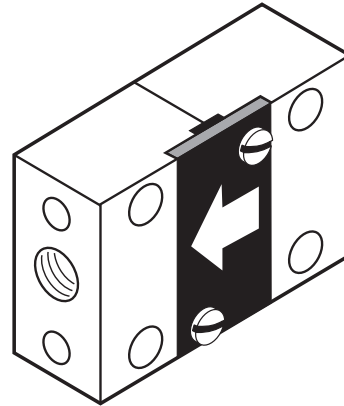

DESCRIPTION

A differential pressure transmitter with an integral orifice assembly forms a complete flow transmitter for the measurement of very low flow rates. With this integral orifice, flow as low as 2.5 gph of water or 24 SCFH of air can be measured.

OPTIMUX's Integral Orifice Assembly is compatible with any XTC differential pressure transmitter or transmitter controller

SPECIFICATIONS

Operating Pressure

Full vacuum to 2000 psig (14 MPa)

Operating Temperature

-40 to 150°C or -40 to 300°F

Materials of Construction

Integral Orifice & Manifold Assembly:

Standard : 316 Stainless Steel

Optional: Hastelloy C-276

O-Ring Seal: Viton

Orifice Accuracy(uncalibrated)

±2% of maximum flow and better than ±1% with Optional Factory Calibration (recommended for viscous application).

COMPLETE ASSEMBLY

Orifice Size	316 Stainless Steel	Hastelloy C-276
	Orifice & Manifold PN	Orifice & Manifold PN
01	20520-304	20520-316
02	20520-305	20520-317
03	20520-306	20520-318
04	20520-307	20520-319
05	20520-308	20520-320
06	20520-309	20520-321

INTEGRAL ORIFICES^{2,3}

Orifice Size	316 Stainless Steel	Hastelloy C-276
01	20520-223	20520-229
02	20520-221	20520-227
03	20520-222	20520-228
04	20520-203	20520-209
05	20520-202	20520-208
06	20520-201	20520-207

MANIFOLD ASSEMBLIES^{2,4}

Material	Part No.
316 Stainless Steel	20520-301
Hastelloy C-276	20520-303

NOTES:

- (1) Capillary flow may produce a transmitter output that will vary from linear to square root. Factory Calibration is recommended for precise sizing and transmitter output data.
- (2) Available for off-the-shelf delivery.
- (3) Requires Manifold Assembly.
- (4) Requires Integral Orifice Assembly.

CAPACITY TABLE 1/2" NPT

Orifice		Liquid ¹ Range (in. H ₂)	Gas ² Flow Rate (gph)	Flow Rate ³ (scfh)
Size	Differential Bore Dia (in.)			
01	0.0250	200	2.5	24
		100	1.8	17
		50	1.2	12
		20	0.8	8
		10	0.5	5
02	0.0390	200	6.3	60
		100	4.4	44
		50	3.1	30
		20	1.9	20
		10	1.3	14
03	0.0625	200	16.6	158
		100	11.7	114
		50	8.3	79
		20	5.2	52
		10	3.6	36
04	0.1250	200	72	683
		100	51	495
		50	36	342
		20	22	225
		10	15	160
05	0.2030	200	191	1811
		100	135	1311
		50	95	906
		20	60	598
		10	42	424
06	0.3430	200	563	5344
		100	398	3870
		50	281	2672
		20	178	1764
		10	126	1250

NOTES:

- (1) Based on water flow at 60°F.
- (2) Based on air flow at 100 psig and 60°F.
- (3) For flow rates lower than those listed, consult OPTIMUX for possible use of glass capillaries.

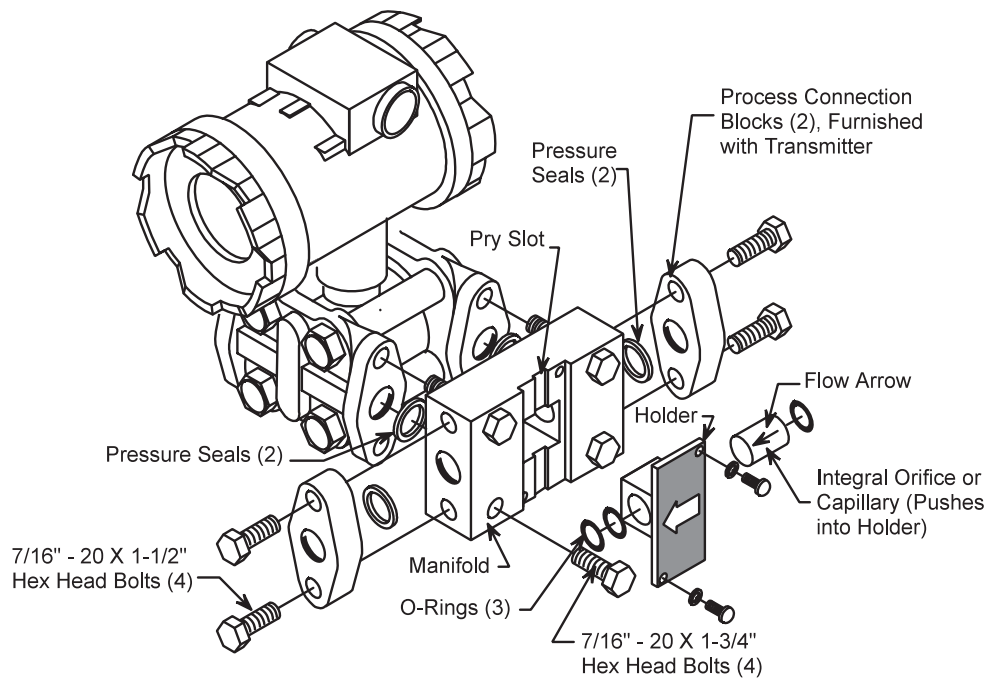

OPTIMUX V140 Fluidic Flowmeter

FEATURES & BENEFITS

- ▶ Specifically designed for high viscosity/low flow rate measurement
- ▶ Rugged construction, which includes no moving parts, allows for installation in various high industrial stress environments
- ▶ The ability to calculate volumetric flow rate unaffected by fluid density ensures accurate flow measurement
- ▶ Rugged meter body with self-contained deflection sensor allows direct, in-line installation into piping
- ▶ The ability to use the Fluidic Flowmeter Deflection Sensor Signal Converter or Fluidic Flowmeter Two-Wire Transmitter provides versatile output selection
- ▶ Choice of 3/4", 1", and 1-1/2" pipe sizes accommodates a variety of applications
- ▶ High immunity from flow overrange or flow surge damage ensures safe operation

DESCRIPTION

The OPTIMUX V140 is a fluidic flowmeter designed for measurement of both nonconductive and conductive liquids at higher viscosities and lower flow rates than conventional flowmeters. These applications include fuel oils #2 through #6, combustion metering of hot/cold fluid mixes, and those where sensor coating problems may occur.

The OPTIMUX V140 includes a rugged meter body with a self-contained deflection sensor for direct, in-line installation into new or existing piping. It integrates with the Fluidic Flowmeter Deflection Sensor Signal Converter or Fluidic Flowmeter Two-Wire Transmitter to provide an output signal for flow rate totalizing, recording, or controlling applications.

The internal design of the OPTIMUX V140 meter body is a fluidic oscillator producing a frequency that is linear to the volumetric flow rate of fluid through the meter. A strain gauge sensor within the meter body detects the oscillations to produce a signal used as input to the Deflection Sensor Signal Converter or Two-Wire Transmitter.

The Fluidic Flowmeter Deflection Sensor Signal Converter provides a dual analog/pulse output. Both a 4-20 mA analog output proportional to the flow rate; and a 12V pulse or transistor switch output scaled in field selectable engineering units are provided. It can be located up to 1000 ft. away from the meter body



The Fluidic Flowmeter Two-Wire Transmitter provides a standard 4-20 mA dc output from the OPTIMUX V140 and can be mounted directly on the meter body, or up to 50 ft. away.

The rugged, reliable OPTIMUX V140 contains no moving parts, minimizing maintenance costs. The design of the meter body does not require maintaining a turbulent flow for sustained oscillation, which allows use with high viscosity liquids at low flow rates to Reynolds numbers as low as 75.

SPECIFICATIONS

Performance

Accuracy: $\pm 2\%$ of flow rate above pipe Reynolds number of 500

Repeatability: 0.25% of rate

Pressure Loss:

10 psi at 5.7 GPM (3/4" meter)

10 psi at 12 GPM (1" meter)

10 psi at 40 GPM (1-1/2" meter)

Capacity

Meter Size	Minimum Flow Rate Greater of	Maximum Full Scale Range ¹ US GPM
3/4"	0.02 GPM/cSt ($R_D = 75$) or 0.35 GPM	0-1/0-8
1"	0.04 GPM/cSt ($R_D = 120$) or 0.75 GPM	0-5/0-17
1-1/2"	0.10 GPM/cSt ($R_D = 200$) or 2 GPM	0-15/0-50

NOTE:

(1) Ranges correspond to 4-20 mA output

Specifications are subject to change without notice.

Pressure Rating

Maximum working pressure of connecting flanges rating per ANSI B16.5.

End Connection Pressure	
150# RF Flange	230 psig
300# RF Flange	600 psig

Temperature

Meter Body: -40 to 350°F (-40 to 175°C)
 Signal Converter: -22 to 122°F (-30 to 50°C)
 Two-Wire Transmitter: -40 to 185°F (-40 to 85°C)

Signal Cable

Signal Converter:
 Meter body must be located within 1000 ft.
 Two-Wire Transmitter:
 Meter body must be located within 50 ft.
 Cable Type: 3-wire, shielded cable, Belden 8771 (or equivalent). This cable is rated for use at temperatures up to 140°F (60°C). For use at higher temperatures, consult OPTIMUX.

Materials of Construction

Process Wetted Parts: 316L SS, Hastelloy C, Viton

MOUNTING DIMENSIONS

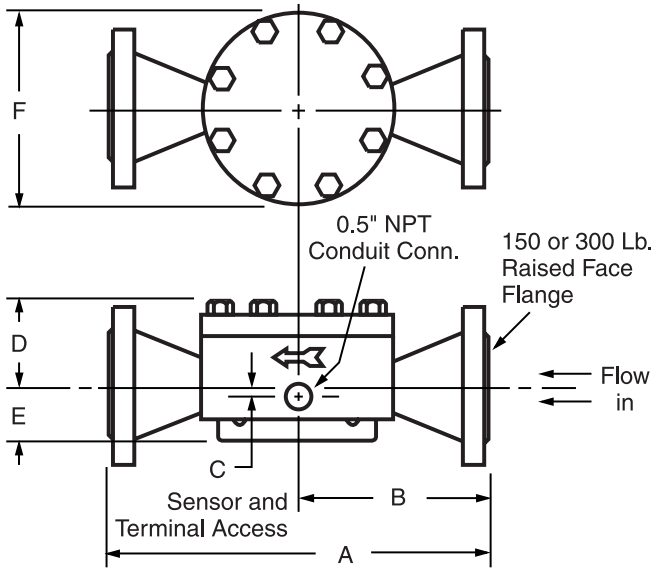

Meter Size	Flange Rating	A	B	C	D	E	F
3/4"	150 lb.	9.45	4.72	0.67	2.08	2.18	5.44
	300 lb.	9.83	4.92	0.67	2.08	2.18	5.44
1"	150 lb.	9.75	4.95	0.28	2.50	1.80	5.44
	300 lb.	10.25	5.19	0.28	2.50	1.80	5.44
1-1/2"	150 lb.	12.72	6.36	0.47	2.92	1.91	7.97
	300 lb.	13.20	6.60	0.47	2.92	1.91	7.97

MODEL SELECTION

V140 Model V140 Fluidic Flowmeter

A Liquid Service

Meter Size
 08 3/4"
 10 1"
 15 1-1/2"

Material
 S Stainless Steel (Type 316L)

End Connections
 1 150# RF Flange
 3 300# RF Flange

Connection Type
 W Welded-On Flanges

Sensor Style
 1 Standard
 2 Long Leads

Electrical Classification
 N Not Required
 F1 FM Approved²

V140 A 08 S 1 W 1 N Sample Model Number

NOTES:

- Order cannot be entered without complete process information.
- FM Approved for the following hazardous locations: Class I, Division 1, Groups A, B, C & D; Class II, Division 1, Groups E, F & G; and Class III, Division 1, when connected per OPTIMUX Drawing 15032-1419 (for Model Q/I Converter) or 15032-1420 (for Two-Wire Transmitter) and installed per manufacturers' instructions.

OPTIMUX V141 Fluidic Flowmeter

FEATURES & BENEFITS

- ▶ The ability to calculate volumetric flowrate that is unaffected by fluid density ensures accurate measurement
- ▶ Rugged construction, which includes no moving parts, allows for installation in various high industrial stress environments
- ▶ Rugged meter body with self-contained deflection sensor allows direct, in-line installation into piping
- ▶ Output selection (analog, scaled pulse, transistor switch) provides application versatility
- ▶ The ability to use the Deflection Sensor Signal Converter or Two-Wire Transmitter provides versatile output selection

DESCRIPTION

The OPTIMUX V141 Fluidic Flowmeter is a rugged, reliable instrument available for a wide variety of fluid measurement applications. Its meter bodies can be selected for a broad range of flow rates, pipe sizes, and pressure ratings. The integral, one-piece design eliminates moving parts, making it ideal for installations subject to vibration. The ability to separately select either a two-wire transmitter or signal converter designed specifically for the OPTIMUX V141 allows the widest flexibility in choosing outputs. Flow measurement applications to be implemented at a minimum of cost, time, and equipment.

The OPTIMUX V141 includes a single-piece, cast meter body with a self-contained sensor available for mounting directly in-line with new or existing process piping. The OPTIMUX V141 operates with the Fluidic Flowmeter Deflection Sensor Signal Converter or the Fluidic Flowmeter Two-Wire Transmitter to provide a signal for recording, indicating, or controlling flow.

The geometric design of the meter body produces a continuous, self-induced oscillation at a frequency corresponding to the velocity of fluid passing through the meter. Oscillations are detected by an enclosed deflection sensor that produces a pulse upon each oscillation. Signals from the sensor are then converted into a scaled pulse and 4-20 mA analog signal (converter) or a single 4-20 mA analog signal (transmitter).

Fluid attaches to one of the side walls within the meter body. A small portion of flow is diverted through a feedback passage to the control port (shown to the right). This feedback flow bends the main flow to the opposite side wall-repeating feedback action and producing oscillation within meter body. Flow-in feedback passage cycles be-



tween zero and maximum. Enclosed deflection sensor varies electrical resistance in response to condition. Resulting signal from the sensor detects frequency of oscillation that is linear to velocity. As such, it detects volumetric flow of fluid through meter.

The Fluidic Flowmeter Deflection Sensor Signal Converter provides both a scaled pulse for flow totalizing and a 4-20 mA signal linearly proportional to the flow rate. Housed in a NEMA 4 enclosure, it can be located up to 1000 ft. away from the meter installation. The Fluidic Flowmeter Two-Wire Transmitter provides a 4-20 mA analog signal proportional to the flow rate. Also housed in a NEMA 4 enclosure, it can be mounted directly on the meter body or connected via cable up to 50 ft. away.

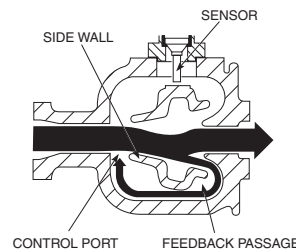

Figure 1

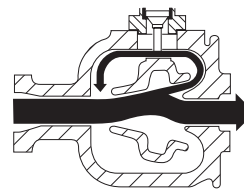

Figure 2

SPECIFICATIONS

Flow Rates

Meter Size	Minimum Flow Rate (GPM)
1"	3.25
1-1/2"	7.6
2"	10.5
3"	23.0
4"	40.0

Listed flow ratings are for water at 60°F, 1 centistoke. To determine flow rates of other fluids, divide the value listed above by the square root of the fluid's specific gravity.

Capacity

Meter Size	Full Scale Calibration Range ¹	
	Minimum GPM	Maximum GPM
1"	0-10	0-55
1-1/2"	0-22	0-130
2"	0-40	0-210
3"	0-125	0-460

Pressure Rating

Maximum working pressure equals connecting flange rating per ANSI B16.5

Meter Size	Connecting Range
1"	150, 300, 600 lb.
1-1/2"	150, 300, 600 lb.
2"	150, 300 ² , 600 lb. ²
3"	150, 300 lb. ² .

Temperature

Meter Body: -40 to +350°F (-40 to +177°C)
 Signal Converter: -22 to +122°F (-30 to +50°C)
 Two-Wire Transmitter: -40 to +185°F (-40 to +85°C)

Materials

Meter Body: Cast Stainless steel
 1" size, type 316 SS (ASTM A296 grade CF8M); 1-1/2", 2" & 3" sizes, type 316L SS (ASTM A296 grade CF3M)
 Sensor: Stainless steel, type 316L SS, and Hastelloy C-276
 Gasket: Teflon, O-Ring: Viton

NOTES:

- Ranges correspond to 4-20 mA output.
- Requires optional welded-on flanges.
- FM approved for intrinsically Safe for Class I/II/III, Div. I, Groups A, B, C, D, E, F, G when used with approved barriers and converters listed on OPTIMUX Dwg. #15032-1419 and -1420 and when installed per OPTIMUX's instructions.
- Dimensions in inches.

Specifications subject to change without notice.

MODEL SELECTION

V141 Fluidic Flowmeter with Deflection Sensor

Meter Body Materials

S Stainless Steel

Meter Size

10 1"
 15 1-1/2"
 20 2"
 30 3"

End Connections

A Water (Flangeless), Standard
 B Welded-on Flanges, ANSI Class 150#
 C Welded-on Flanges, ANSI Class 300#
 D Welded-on Flanges, ANSI Class 600#²

Deflection Sensor Style

A Standard Leads
 B Long Leads

Options

N None
 A With Mounted 2-Wire Transmitter

Electrical Approval

N Not Required
 F² FM Approved

V141 S 10 A A N N Sample Model Number

DIMENSIONS

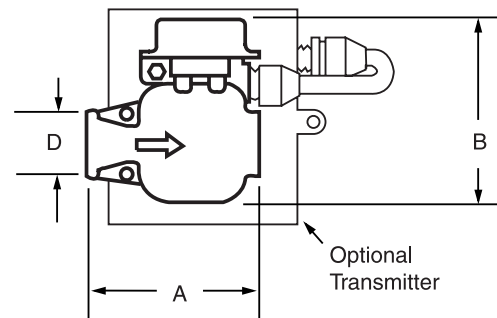
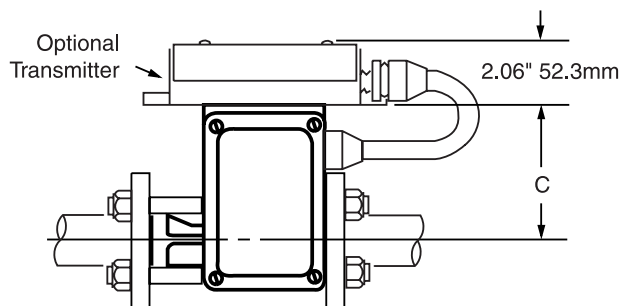

Meter Size ⁴	A	B	C	D
1"	5.50	5.88	4.12	2.00
1-1/2"	7.63	7.57	4.25	3.25
2"	8.06	8.04	4.25	4.00
3"	11.72	10.88	4.25	5.00

Fluidic Flowmeter Two-Wire Transmitter

FEATURES & BENEFITS

- ▶ Provides accurate, reliable metering of process fluids
- ▶ Provides a standard 4-20 mA signal for use with electronic indicators, recorders, or controllers
- ▶ The ability to operate in hazardous areas accommodates installation in high industrial stress areas
- ▶ Accurate frequency source, multi-meter, and 10-40 Vdc power supply facilitate easy wiring connections, calibration, and adjustment
- ▶ High rangeability
- ▶ Wall, pipe, and meter body installation options provide application versatility

DESCRIPTION

The Fluidic Flowmeter Two-Wire Transmitter provides a standard 4-20 mA_{dc} electronic signal from the OPTIMUX V140 and V141 Fluidic Flowmeters. This sturdy, one-piece unit can be installed in a variety of locations, including hazardous areas, to provide reliable, cost-effective flow measurement. As such, it can serve as an input for the flow rate to a wide variety of electronic indicating, recording, or controlling equipment. The self-induced oscillation of fluid within the meter body is detected by the deflection sensor, which generates pulses proportional to the rate. The transmitter converts the frequency of pulses into a corresponding analog signal.

The Fluidic Flowmeter Two-Wire Transmitter consists of a one-piece cast aluminum enclosure with separate compartments for the terminal block for field wiring and a single printed circuit board that converts pulse frequency into the analog signal. Two screw-mounted gasketed, removable panels allow access for wiring connections, calibration, and adjustment. The Two-Wire

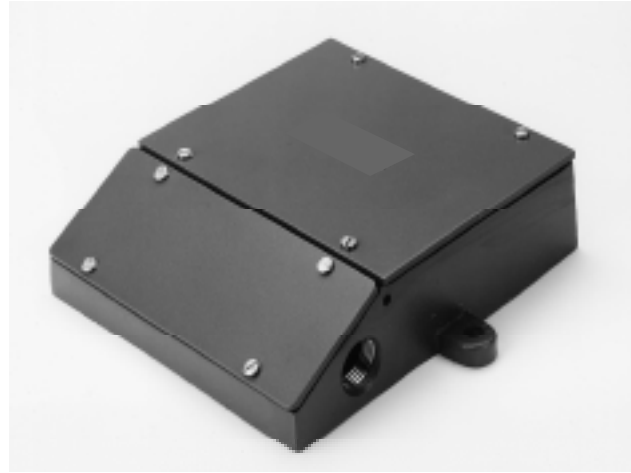

Transmitter can be surface mounted or pipe-mounted with an accessory bracket. It can also be mounted directly to the OPTIMUX V140 meter body with a 1/2" pipe nipple or bolted to the OPTIMUX V141 meter body. Two 1/2" NPT connections in the enclosure allow wiring or a conduit to be installed for connections to the meter body, power supply, and external device. Intrinsically safe operation in hazardous areas can be implemented with installation of appropriate energy limiting barriers.

Calibration and adjustment of the transmitter are easily performed using an accurate frequency source, a multimeter, and 10-40 Vdc power supply. Switches on the board provide coarse span resistance. Jumper plug connections allow selection or change of response time from 10 to 4 seconds. Static pressure and hysteresis adjustment are accessible directly on the board with no further equipment or disassembly required.

SPECIFICATIONS

Accuracy

Calibration Accuracy: ±0.10%, full scale.

Analog Output

4-20 mA, standard calibration.

Power Supply

Requirements: 10 Vdc at 0 ohm load (min.)
40 Vdc at 1500 ohm load (max.)

Field Connections

Six position terminal block. Accessible from sealed, removable panel.

Sensor Cable

Transmitter may be located within 50 ft. of meter body with 3-wire, shielded cable, Belden 8771 (or equivalent). This cable is rated for use at temperatures up to 140°F (60°C). For use at higher temperatures, consult OPTIMUX.

Enclosure

NEMA 4

Construction

Cast Aluminum

Environmental

Temperature Range: -40 to +185°F (-40 to +85°C)
Relative Humidity: 5% to 100%

Electrical Classification

FM approved as intrinsically safe for operation in: Class I, II, III, Div. 1, Groups A, B, C, D, E, F & G when used with approved barriers listed on OPTIMUX Dwg. #15032-1420, and installed per OPTIMUX's instructions.

ACCESSORIES

Pipe Mounting Kit

Includes universal bracket, U-bolt and all associated hardware.

Sensor Cable Kit

Includes 50 ft. of 3 wire shielded cable and mounting hardware.

INSTALLATION DRAWING

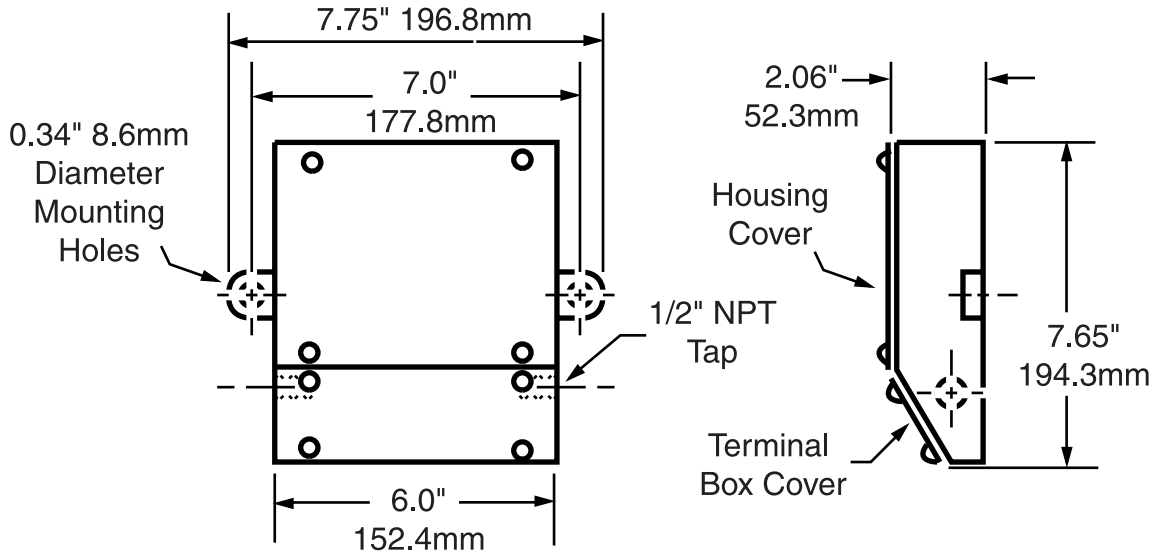

Dimensions are in Inches (Millimeters)

Fluidic Flowmeter Deflection Sensor Signal Converter

FEATURES & BENEFITS

- ▶ Provides dual analog/pulse output options for application versatility
- ▶ Field selectable engineering units of pulse output provides flow totalizing
- ▶ Accurate frequency source and digital multimeter facilitate easily accessible wiring connections, calibration, and adjustment.
- ▶ The ability to be located up to 1000 ft. away from meter body provides application versatility

DESCRIPTION

The Fluidic Flowmeter Deflection Sensor Signal Converter provides a dual analog/pulse output from the OPTIMUX V140 and V141 Fluidic Flowmeters. Both a standard 4-20 mA signal and a 12V pulse or transistor switch output are provided proportional to the flowrate. These outputs can be used with other instruments for a wide variety of process totalizing, recording, indicating, or control applications.

The oscillation of fluid through the body produces a signal in the deflection sensor proportional to the flowrate. The Fluidic Flowmeter Deflection Signal Converter filters and conditions the signal and converts it to the corresponding analog and pulse outputs.

The Converter consists of two printed circuit boards and electrical connections mounted in a NEMA 4 enclosure. Switch and jumper plugs allow output pulses to be scaled in engineering units. Pulses can be selected as positive-going, 12V scaled pulses referenced to circuit common; or negative-going 12V scaled/unscaled pulses referenced to +12V. Additionally, circuit board and user wiring changes can be made for high/low impedance loads, or to an open collector transistor switch. Output, input, and power wiring are connected via screw terminals within the enclosure. Calibration can be performed with an accurate frequency source and digital multimeter.



MODEL SELECTION

14CNB	Deflection Sensor Signal Converter
	Range Designation
00-99	(Selected by OPTIMUX based on meter size and flow rate.)
	Output Response
S	Standard
	Power Supply
1	120 Vac, 50-60 Hz
	Electrical Approval
F1	FM Approved
14CNB16 S 1 F1	<i>Sample Model Number</i>

SPECIFICATIONS

Accuracy

Analog Output: $\pm 0.1\%$, full scale

Input

Fluidic Flowmeter Deflection Sensor
(Models V140 and V141)

Output

Analog

Type: Isolated 4-20 mA_dc
Maximum Load: 600 ohms
Maximum Current: 35 mA_dc
Maximum Voltage: 18.9 V_dc
Span Adjustment: 30% of Maximum span

Pulse

Load Resistance: 60 ohms (max.)
Maximum Current: 200 mA_dc
Maximum Voltage: 35 V_dc
Saturation Voltage: 0.4 V_dc at 100 mA

Open Collector Pulse

Load Resistance: 60 ohms (min.)
Maximum Current: 200 mA_dc
Maximum Voltage: 35 V_dc
Pull-Up Voltage: 12 V_dc, 5%

Pulse Characteristics

Rise/Fall Time: 1 msec. with 0.005 mF (max.)
Unscaled Pulse Width: 2-10 msec.
(Depending on meter size)
Scaled Pulse Width: 50-70 msec.

Power Supply

Requirements:
120V, +10%, -15%, 50-60 Hz. 13W (max.)

Enclosure

NEMA 4

Sensor Cable

Signal Converter can be located within 1000 ft. of meter body with 3-wire, shielded cable, Belden 8771 (or equivalent). This cable is rated for use at Temperatures up to 140°F (60°C). For use at higher temperatures, consult OPTIMUX.

ENVIRONMENTAL

Temperature: -22 to +122°F (-30 to +50°C)
Relative Humidity: 5% to 100%

Electrical Classification

FM approved as non-incendive for Class I, Div. 2, Groups A, B, C & D. Has intrinsically safe connections for Class I, Div. 1, Groups A, B, C & D without energy limiting barriers when used with OPTIMUX V140 and V141 Fluidic Flowmeters having a deflection type sensor and installed per OPTIMUX's instructions.

MOUNTING DIMENSIONS

